



Product specification

The DCS3-070720 piezoelectric stack consists of multiple chips which are bonded via epoxy. It offers a maximum displacement of 22.0 μ m. A red wire is attached to the electrode that should receive positive bias, and a black wire is attached to the electrode that should be grounded.



DCS3-070720

Performance Parameters

Drive Voltage Range	-30~150 V	Capacitance	3.2 μ F \pm 15%
Displacement (Free Stroke) at 150 V	22.0 μ m \pm 15%	Dissipation Factor	<2.3%
Hysteresis	<15%	Resonant Frequency	63kHz
Stiffness	89N/ μ m	Blocking Force at 150 V	1960N
Curie Temperature	230 °C	Operating Temperature	-25 ~ 130 °C
Product Size	L: 7.0mm	Outer Dimensions	L: 7.3 \pm 0.2mm
	W: 7.0mm		W: 9.1 \pm 0.2mm
	H: 20.0mm		H: 20.0 \pm 0.1mm

- All specifications are quoted at 25°C, unless otherwise stated.
- The moisture-proof coating material is 353ND, please refer to the TDS of 353ND for relevant materials.



Product specification

Product Size

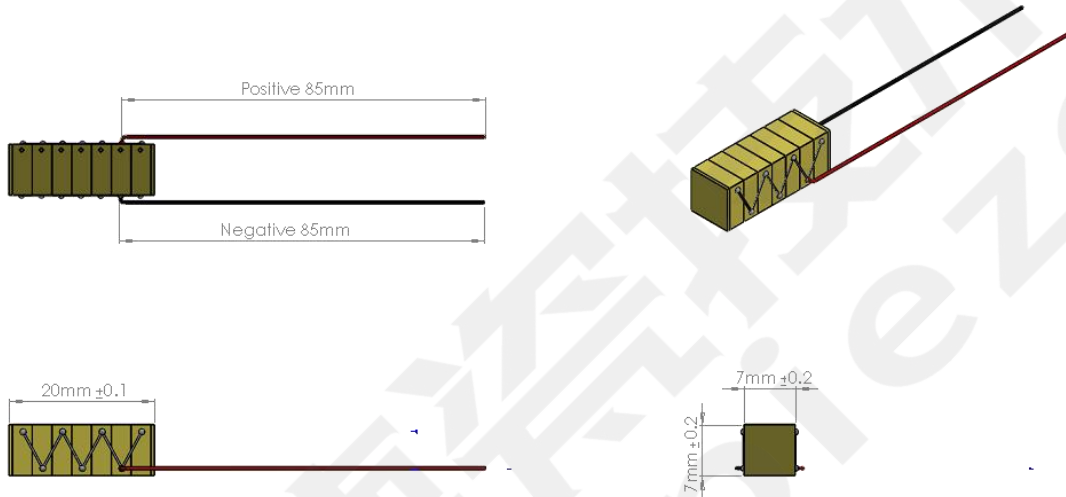

Performance

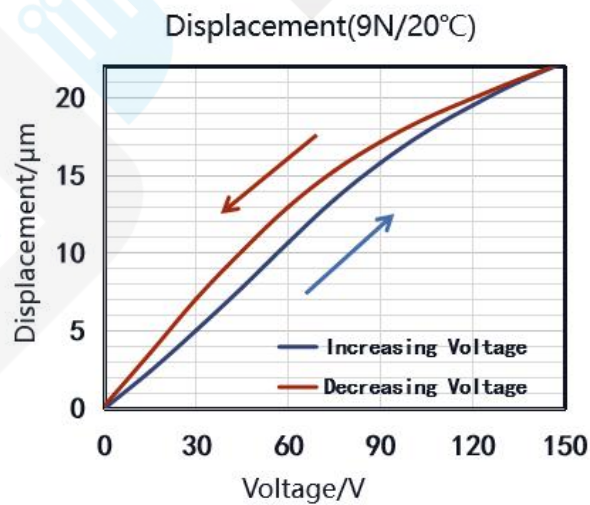

- These temperature rises were measured after applying a sine-wave drive voltage ranging from 0 to 150V at the specified frequency for 10 minutes.



Product specification

Matters Needing Attention

◆ Storage environment and precautions:

The temperature is below 50 °C; Humidity below 40% Rh; Avoid collisions and squeezing; Suggest long-term storage in vacuum bags; Connect resistor discharge ($\geq 100k \Omega$) or short circuit (low capacity ceramic) during non use;

◆ Operating environment and precautions:

The upper limit of ceramic working temperature is 120 °C (preferably below 60 °C). When the ceramic temperature exceeds 80 °C, it is recommended to increase heat dissipation measures; The humidity is less than 50% (in high humidity environments, it is best to use a low-pressure heat engine first, otherwise it is prone to creepage); Avoid dust (dust is easily adsorbed on the ceramic surface, reducing its insulation impedance); It is recommended that the gap between ceramics and other conductors be greater than 1.6mm; Do not immerse the piezoelectric stack in organic solvents or near flammable gases or liquids.

◆ Precautions during assembly process:

The red wire from the piezoelectric stack electrode is the positive electrode of the product, and the black wire is the negative electrode of the product grounded. Reverse electrode connection can cause mechanical failure. During transportation and assembly, handle with care to avoid impact; Wear gloves to avoid oil stains; The gap fit between the assembly parts should be maintained first, and finally locked to avoid interference fit and squeeze the ceramic; Maintain a distance of at least 1.6mm between ceramics and accessories to avoid electrostatic impact; When the assembly process involves bonding, the bonding surface should be kept flat, excess glue should be removed, and surface pollution should be reduced; When welding is involved in the assembly process, the time should be controlled, and the contact time at high temperatures should be less than 1 second to reduce the damage of high temperatures to ceramics and paint surfaces;



Product specification

When assembly requires prolonged high temperatures, the temperature should be controlled below 120 °C to avoid issues such as product depolarization, glue breakage, and paint damage.

◆ Pre load instructions:

It is recommended to apply an external load to the piezoelectric stack, which should be attached to the center of the stack installation area or evenly distributed on the installation surface as much as possible to ensure that the two surfaces in contact with the stack are highly flat and smooth. Piezoelectric stacks can only withstand axial forces, and shear or torsion forces may cause mechanical failures. It is recommended that the pre tightening force should not exceed 40% of the maximum output and the direction should be consistent with the direction of movement to reduce the shear force on the ceramic.

